

HYBRID KANGAROO – ASSEMBLY INSTRUCTIONS

ASSEMBLY PARTS LIST

- A. (1) 5/32 Allen Wrench
- B. (10) Black Screw Covers
- C. (1) 7/16 Wrench
- D. (2) Fender Washers
- E. (2) 1/4-20 x 3.50 Hex Head bolts
- F. (2) Acorn Nuts
- G. (2) Thick Black Washers
- H. (3) 1/4-20 x 7/8 BHCS
- I. (2) Locking Star Washers



Unit is shipped with (4) bolts and washers threaded into the vertical rails of the laptop shelf support

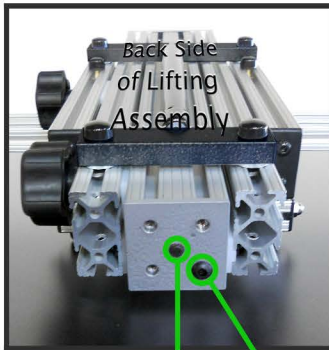

STEP 1

Threads of Spring
Single Button Screw



STEP 2

Oversize Holes

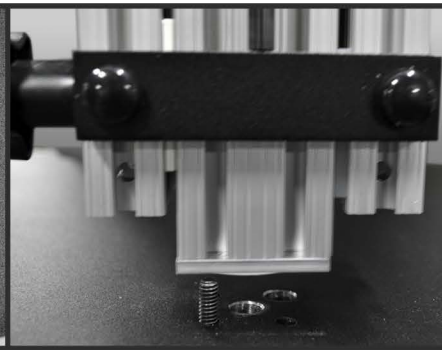

STEP 3

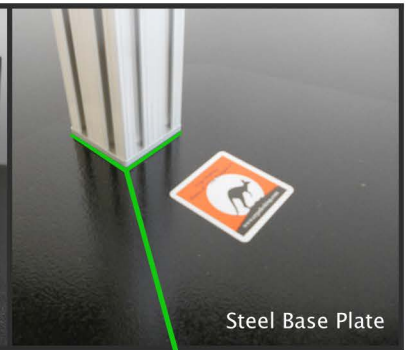

STEP 4

Lifting assembly should be flat against the base when tight.

Step 1: Lay the lifting assembly on a solid surface with the back side up as shown. Notice the single Button Head Bolt and the Threads of the Spring in the assembly union. **DO NOT LOOSEN THE SINGLE BUTTON HEAD BOLT.**

Step 2: Now notice the (2) oversized holes in the Base Plate. The Single Button Head Bolt and the Threads of the Spring will go into these oversized holes.

Step 3: With the Base Plate over hanging the table about 2 inches, hold the Lifting Assembly above the Base Plate and align the Single Button Bolt and the Spring Threads into the oversized holes. Place one 1/4-20 x 7/8 BHCS through the base plate to screw in the lifting assembly.

Step 4: Insert and thread the other (2) 1/4-20 x 7/8 BHCS through the Base Plate and into the Lifting Assembly. Once all (3) bolts are threaded in, tighten securely with the 5/32 allen wrench. Lifting Assembly should be flat against the Base.

HYBRID KANGAROO – ASSEMBLY INSTRUCTIONS

STEP 8

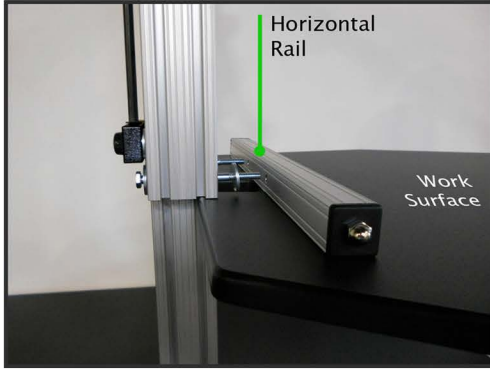

Step 8: Lift the Work Surface up and align the holes in the Horizontal Rail with the (2) 1/4-20 x 3.50 Hex Head Bolts. Push the Work Surface onto the Hex Head Bolts until the threads of the bolts come through the Horizontal Rail.

STEP 9



Step 9: Put (1) Black Washer and (1) Acorn Nut on the end of each of the Hex Head Bolts. Using the 7/16 wrench tighten the Acorn Nuts securely.

STEP 10



Step 10: Remove the (4) 1/4-20 x 1.0 hex head bolts and (4) washers from the bottom of the Monitor Lifting Assembly.

STEP 11, 12



Step 11: Position the Laptop Shelf below the lifting assembly and align the holes in the Laptop Shelf with the threaded holes in the Monitor/laptop Lifting Assembly.



Step 12: Thread the (4) hex head bolts into the threaded holes in the Lifting Assembly to secure the laptop shelf to the unit. Tighten securely with a 7/16 wrench.

STEP 13 MOUNTING YOUR MONITOR

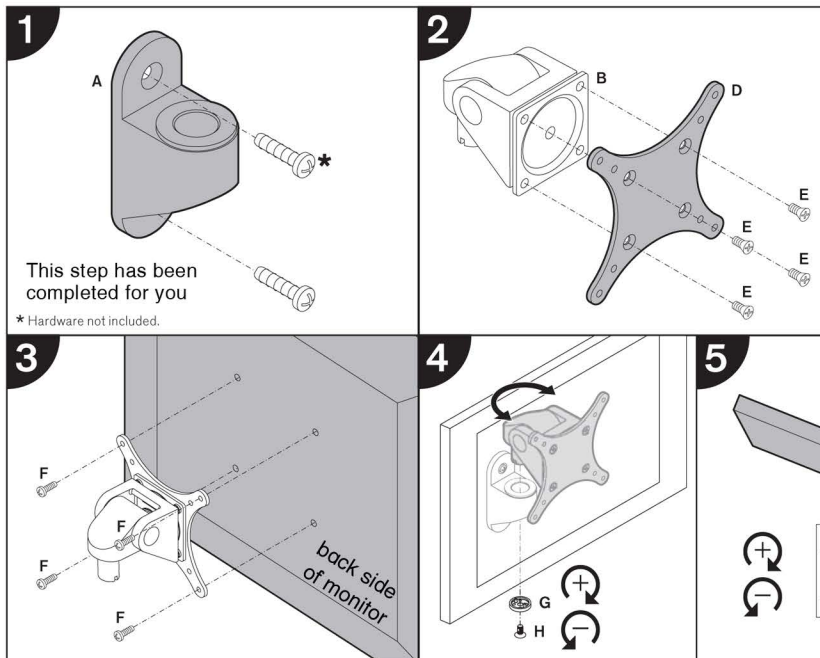

STEP 5

The monitor will need to be faced towards the ceiling to reach the bottom adjustment bolt in the filter mechanism. Use the 7/32 allen wrench provided with the kit to tighten the bolt.

MODEL 9110 Parts List

ITEM	DESCRIPTION / PART NO.	9110
A	Wall Mount RP406795	1
B	Monitor Tilter 405397	1
D	75mm/100mm VESA® Adapter Plate 105587	1
E	10-32 x 3/8" Phillips Flat Head Screw 702281	1 (set of 4)
F	M4-12 Phillips Pan Head Screw 702096	1 (set of 4)
G	Dog Washer 105189	1
H	10-32 x 3/8" FPhMS w/Lock Patch 705198	1
I	7/32" Allen Wrench 701127	1

THE HYBRID KANGAROO

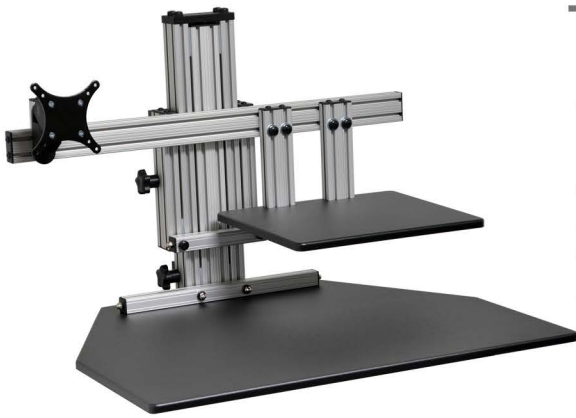

The Hybrid Kangaroo is designed to hold (1) LCD Monitor on the VESA 75 x 75 or 100 x 100mm compatible bracket, a laptop on the shelf and your keyboard and mouse on the main work surface. Your Hybrid Kangaroo is shipped in the down position with the Main Brake tightened. The Hybrid Kangaroo has (2) springs that assist in raising your unit to the standing position and works best when your monitors and keyboard are in place. This reduces the amount of pressure needed to lower the unit. **Always push down with both hands on the horizontal rear rail when lowering the main work surface.**

To move the shelf horizontally closer or farther apart, simply remove the black caps with a flat head screw driver and loosen the bolts attached to the **horizontal monitor rail (B)** by a 1/2 a turn with a 7/16 wrench. Once you have reached the desired position re-tighten the bolts.

To move the mount horizontally closer or farther apart, simply loosen the **bolt** attached to the **horizontal monitor rail (B)** by a single turn with an 5/32 allen wrench. Once you have reached the desired position tighten the bolt.

HOW TO USE THE HYBRID

To raise the Hybrid, loosen the main brake(D) and lift the main work surface on the sides(E & E). Once you have the work surface at the required height tighten the main brake.

To lower the Hybrid, loosen the main brake(D) and lean into the unit using your upper body weight pushing down with both hands on the horizontal bar at the rear of the main horizontal work surface(C & C).

Raise and lower the monitor rail by loosening the monitor brake(A) and either lift up or push down on the monitor rail(B). Once the monitors reach your desired level, tighten the monitor brake.

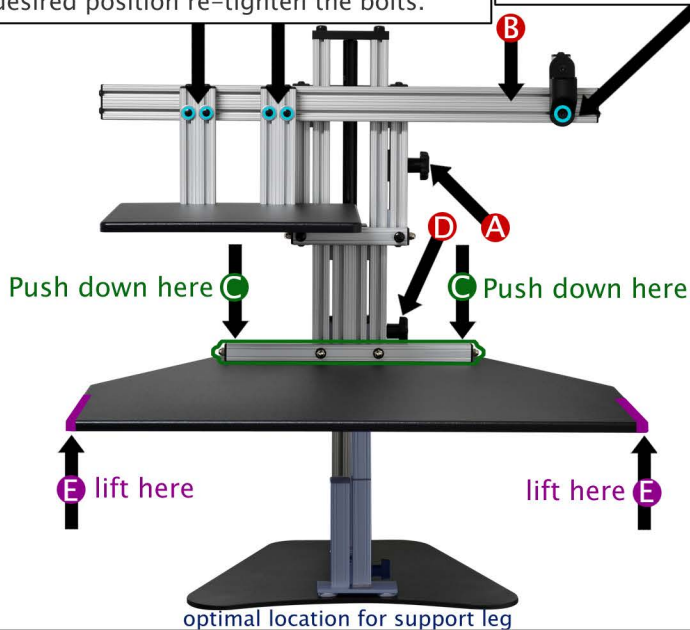

A. Monitor Brake

C. Work Surface Rail

B. Horizontal Monitor Rail

D. Main Brake

E. Main Work Surface

↓ MOUNTING YOUR MONITOR

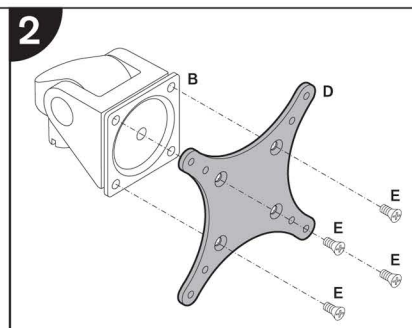
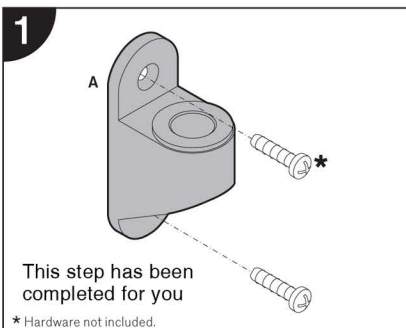

STEP 5

The monitor will need to be faced towards the ceiling to reach the bottom adjustment bolt in the tilter mechanism. Use the 7/32 allen wrench provided with the kit to tighten the bolt.

MODEL 9110

Parts List

ITEM	DESCRIPTION / PART NO.	9110
A	Wall Mount RP406795	1
B	Monitor Tilter 405397	1
D	75mm/100mm VESA® Adapter Plate 105587	1
E	10-32 x 3/8" Phillips Flat Head Screw 702281	1 (set of 4)
F	M4-12 Phillips Pan Head Screw 702096	1 (set of 4)
G	Dog Washer 105189	1
H	10-32 x 3/8" FPhMS w/Lock Patch 705198	1
I	7/32" Allen Wrench 701127	1

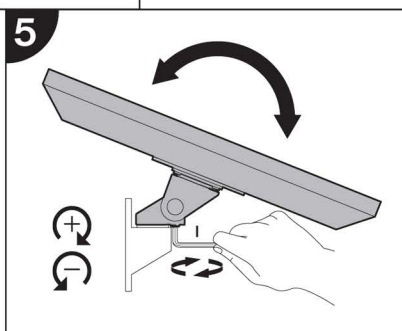
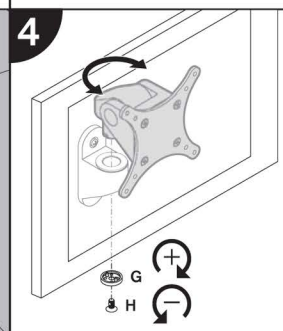
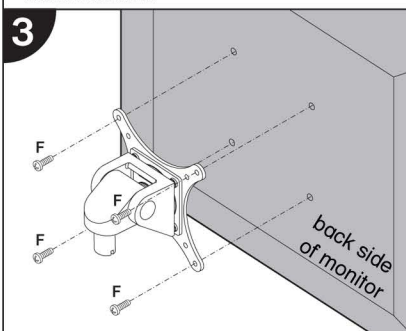

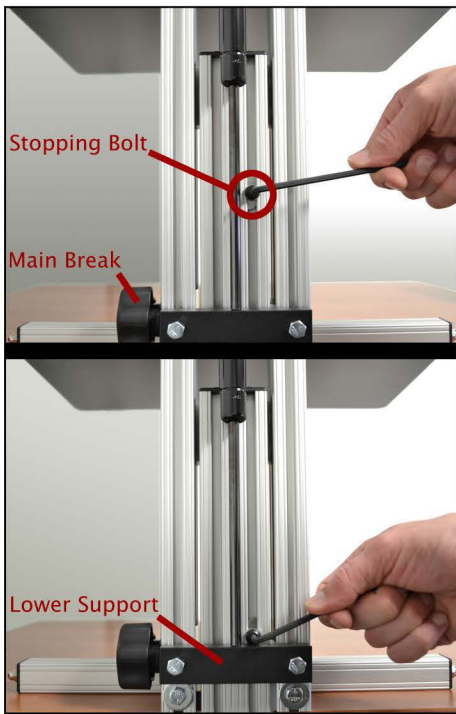

ADJUST STOPPING BOLT

On the back side of your unit you will notice a small bolt located on the lifting tower. This bolt is used as our work surface stopper. It is currently set at 15", the highest our unit should go. This setting is for a 6'2" user on a 30" high desk. If you are shorter than this, raise the unit to your desired height and tighten the Main Brake. Adjust the stopping bolt by loosening the bolt **with one turn** and drop the bolt down to reach the lower support, and re-tighten the stopping bolt.

If you are a taller individual and need to raise the stopping bolt, please note that the work surface can get up to 16 1/2 inches but you will be raising the unit into the oil dampening zone of the spring. This makes it a little more difficult to lower the unit into the seated position when raised to this maximum point.

Our work surface should only be raised to your belt or navel line. This creates a 90-110 degree angle in your elbows which is suggested in the standing position. This will also allow you to lower the unit with ease by simply transferring your upper body weight into the back of the unit.

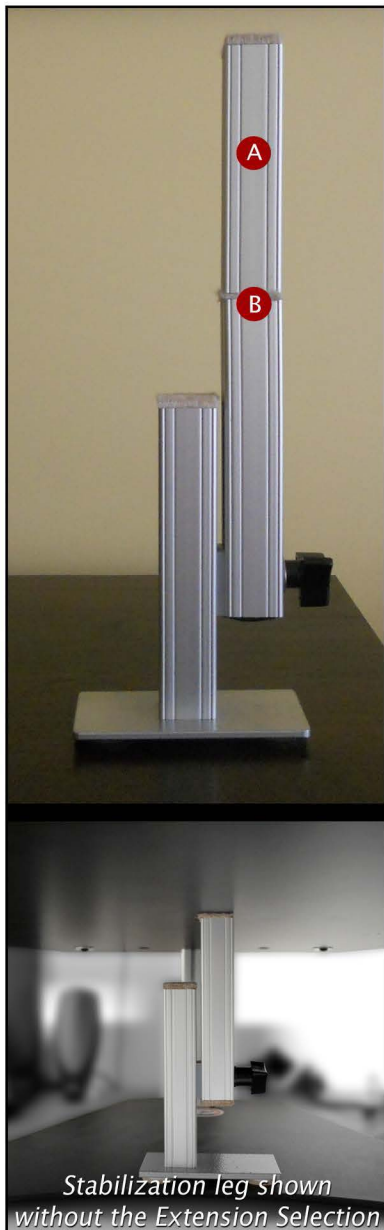

THE STABILIZATION LEG

Your adjustable height desk top unit comes with an adjustable leg that can be used to give you maximum stability when you are using "The Kangaroo" in the standing position.

Raise the Kangaroo work surface to your desired standing height and tighten the work surface brake.

Place the adjustable leg under the work surface and loosen the adjustable leg brake. Only loosen the brake by a turn or two, too much and the brake will disengage from the slot.

Extend the adjustable leg until it engages the bottom of the work surface and then tighten the adjustable leg brake.

The leg is shipped with the **extension section** installed to give you additional height adjustment. If this is too tall for your application, simply **unscrew the extension selection**.

- A** Extension Selection
- B** screws into here

ALWAYS REMOVE LEG BRACE BEFORE LOWERING THE WORK SURFACE.